

A DVD Spectroscope: A Simple, High-Resolution Classroom Spectroscope

Fumitaka Wakabayashi*

Department of Science and Engineering, National Science Museum, Shinjuku-ku, Tokyo 169-0073, Japan;

*f.waka@kahaku.go.jp

Kiyohito Hamada

Department of Education, National Science Museum, Taito-ku, Tokyo 110-8718, Japan

Observing spectra is an effective way to get students interested in light and color and, further, in spectroscopy. Various simple spectroscopes and demonstration methods of spectra suitable for classroom experiments have been published (1–4). Compact disc (CD) spectroscopes have been proposed and are widely used in classrooms because they can easily be made with common materials and give impressive spectra (5, 6). However, the resolution of CD spectroscopes is relatively low: it is often the case that the spectral lines of atomic spectra are observed as blurred lines. Specifically, CD spectroscopes cannot resolve the two yellow spectral lines of mercury at 577 and 579 nm.

Digital versatile disks (DVDs) are now in widespread use as recording media of video and computer data (7). The recording tracks are spaced by $0.74\ \mu\text{m}$, making a grating of about 1350 lines/mm. This spacing is much smaller than that of CDs ($1.6\ \mu\text{m}$, 625 lines/mm) and comparable to the gratings in spectrophotometers routinely used in laboratories. Thus a DVD has a potential to be used as a high-resolution monochromator. While many have suggested that DVDs can be used as a grating instead of CDs (8), one can take full

advantage of DVDs as gratings only if a spectroscope is designed for the purpose. We describe a simple DVD spectroscope that can resolve the yellow spectral lines of mercury at 577 and 579 nm.

Construction of the DVD Spectroscope

The design of the spectroscope is shown in Figure 1. The spectroscope can be made with a sheet of cardboard or an empty box such as a facial tissue box. The critical dimension is the DVD inserting angle of about 60 degrees from the bottom plane of the spectroscope. An example of the paper pattern for the spectroscope is shown in Figure 2. This pattern can easily be copied on a sheet of letter-size or A4-size cardboard. An entrance slit, a DVD inserting port, and a viewing window must be cut. The width of the slit is not as critical as in the CD spectroscope, but a width of 0.5 mm is recommended to achieve good resolution. This paper pattern can also be used for a CD spectroscope if the “CD inserting port” is cut. In this case, the inserting angle for the CD is set at about 50 degrees.

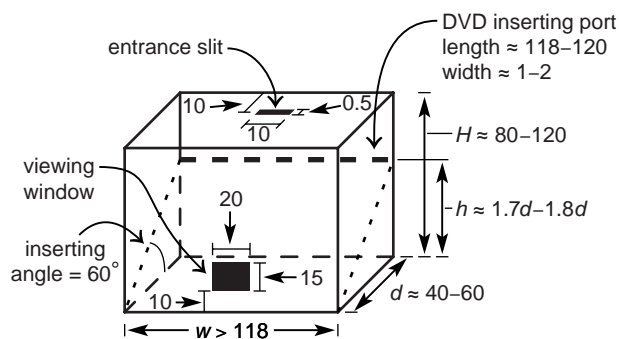

Figure 1. A plan of DVD spectroscope (dimensions in mm).

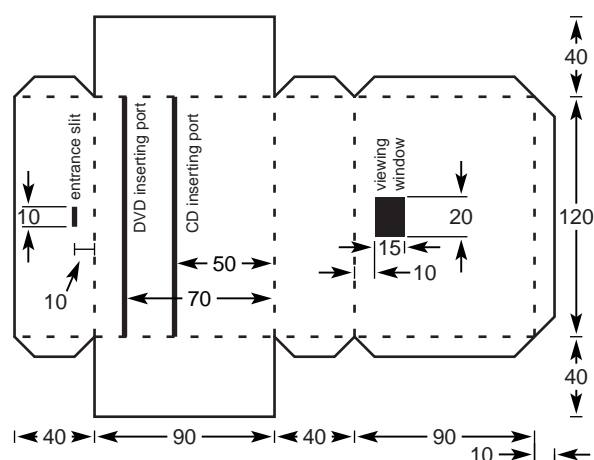

Figure 2. An example of the paper pattern of the DVD spectroscope. This pattern also serves as that of a CD spectroscope if “CD inserting port” is cut (dimensions in mm).

Single-sided (4.7 GB) or double-sided (9.4 GB) single-layer-type DVDs can be used, such as movie DVDs, DVD-ROMs, or DVD \pm R/RWs (7). Dual layer-type DVDs, however, cannot be used. A DVD-RAM disk gives spectra of relatively low resolution at different positions on the disk because of different spacing from the above mentioned DVDs. If the reflective side of the DVD is colored, caution must be exercised when viewing the spectra as the reflective side, itself, has absorption bands.

To reduce stray light, it is recommended that the DVD be covered with a mask as shown in Figure 3. This mask can be made with an envelope or paper and serves to prevent light that may leak into the box or result from multiple reflections from complicating the observations. This simple method improves the quality of the spectra.

A DVD is inserted in the inserting port until the top of the DVD touches the inside edge of the box below the viewing window. The reflective side of the DVD should face the viewing window.

Observation and Taking Photographs of Spectra

One can easily observe various emission spectra of light sources and absorption spectra of colored materials using the DVD spectroscope in the same way described in our previous article (5). Photographs of the observed spectra can easily be recorded by a digital camera. The lens of the camera should be attached to the viewing window. We manually set the focal point at 1.2 m. Such images can be displayed on a monitor in real time, which helps students to understand what is observed in the spectroscope.

Emission Spectra

A spectrum of a typical fluorescent lamp is shown in Figure 4. Both a continuous spectrum due to the white fluorescent material and the spectral lines due to the mercury vapor in the lamp are clearly observed. It is noted that the two yellow spectral lines of mercury are distinctly resolved as shown in Figure 4B.

Another advantage of the DVD spectroscope is that it gives clear and fine spectra that cannot be obtained by using CD spectroscopes. For an example, many Fraunhofer lines are clearly observed in the sunlight spectrum. The light from blue sky or cloud, or the reflection light from a light-colored building is sufficient to observe the Fraunhofer lines. Streetlights and discharge lamps are also interesting objects to be observed (3, 9). Spectra of the H₂, He, Ne, and N₂ discharge lamps are shown in Figure 5. Clear and fine spectra are observed: for the details of the spectra, refer to the literature (3, 9).

Hazards

Looking at the reflection from strong sunlight can damage your eyes. If the reflected light is painful or difficult to look at, look away at once.

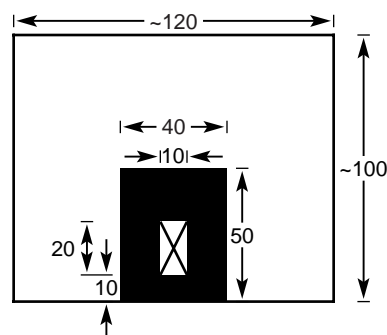

Figure 3. An example of DVD mask, which can be made with an envelope or paper. The center of the blackened part should be cut in a rectangle (dimensions in mm). The dimensions of the blackened area are not critical, and the whole mask can be made of black paper. This mask should be inserted so that the hole is visible in front of the viewing window.

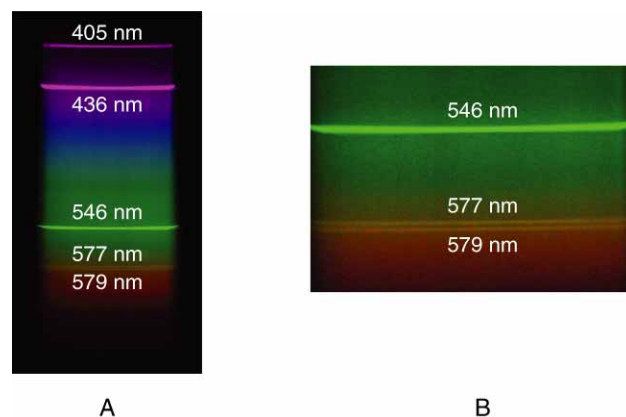

Figure 4. Visible spectrum of a traditional fluorescent lamp observed with the DVD spectroscope: (A) whole spectrum and (B) in the region of 578 nm.

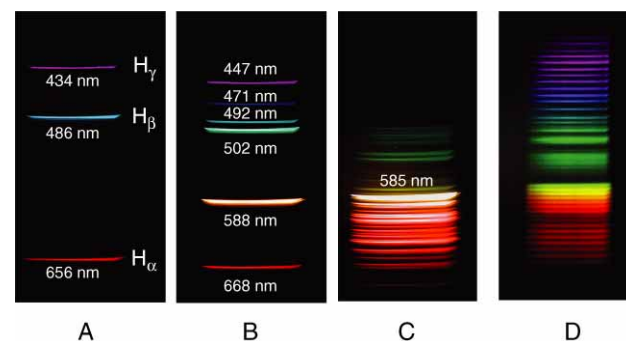

Figure 5. Emission spectra of discharge tubes observed with the DVD spectroscope: (A) hydrogen, (B) helium, (C) neon, and (D) nitrogen.

Conclusions

Using a DVD, we have successfully made up an inexpensive but high-resolution spectroscope suitable for classroom experiments: the spectroscope has enough resolution to distinctly resolve the yellow spectral lines of mercury at 577 and 579 nm. This spectroscope can easily be made with common materials and gives clear and fine spectra of various light sources and colored materials. The observed spectra can easily be photographed with a digital camera. Such images can be displayed on a monitor in real time, which help students to understand what is observed in the DVD spectroscope.

Acknowledgment

This work was partially supported by Grant-in-Aid for Scientific Research on Priority Areas (008) No. 17011078 from the Ministry of Education, Culture, Sports, Science and Technology of Japan.

Literature Cited

1. Edwards, R. K.; Brandt, W. W.; Companion, A. L. *J. Chem. Educ.* **1962**, *39*, 147–148.
2. Cortel, A.; Fernández, L. *J. Chem. Educ.* **1986**, *63*, 348–349.
3. Jacobs, S. F. *J. Chem. Educ.* **1997**, *74*, 1070.
4. Solomon, S.; Hur, C.; Lee, A.; Smith, K. *J. Chem. Educ.* **1994**, *71*, 250–251.
5. Wakabayashi, F.; Hamada, K.; Sone, K. *J. Chem. Educ.* **1998**, *75*, 1569–1570. *JCE* Editorial Staff. *J. Chem. Educ.* **1998**, *75*, 1568A–1568B.
6. Knauer, T. *Phys. Teach.* **2002**, *40*, 466–467.
7. Birkett, D. *J. Chem. Educ.* **2002**, *79*, 1081–1087, and references cited therein.
8. Field, S. Q. Science Toys You Can Make With Your Kids, Chapter 7: Light and Optics. http://www.scitoys.com/scitoys/scitoys/light/cd_spectroscope/spectroscope.html (accessed Oct 2005).
9. Goode, S. R.; Mets, L. A. *J. Chem. Educ.* **2003**, *80*, 1455–1459.